

ESAB CaB 460S

A Standard Column and Boom for flexible weld mechanization

Observe the advantages:
Competitive price range for standard volume products.
Shorter delivery time by adapted modules.

Improved by:

- Competitive delivery time.
- Tachometer as an option for controlled welding motion, as well as for wire feed.
- Electrically designed to fit either welding with or without camera supervision.
- Joint tracking with camera supervision.
- Option for built in flux feed/gas feed control into remote control.
- Universal anti-tipping device to fit several types of rail.
- A larger selection of adapted welding heads.

With obvious benefits:

- Consistent quality
- Reduced door-to-door time
- Improved environment for the operator

Add on modules:

A full range of easily installed welding and auxiliary equipment modules is standard for the station. For information about the program, see technical data sheet.

Large working ranges...

CaB 460S has a working range - from 5 to 7 m both vertically and horizontally. The $\pm 180^\circ$ column rotation facility provides a total action radius.

...and sufficient load capacities

The 6x6 size is capable of 350 kg load at the end of the rack and pinion driven boom.

Sufficient to carry a fully equipped welding head for high productive submerged arc or gas metal arc welding.

Productivity...

The A2 or A6 welding systems with Process Controller PEH are easily combined with CaB 460S to control longitudinal or circumferential welding. A standard built-in swivel bracket at the end of the boom can position the welding head either for welding speed from the boom or from the mobile concrete carriage.

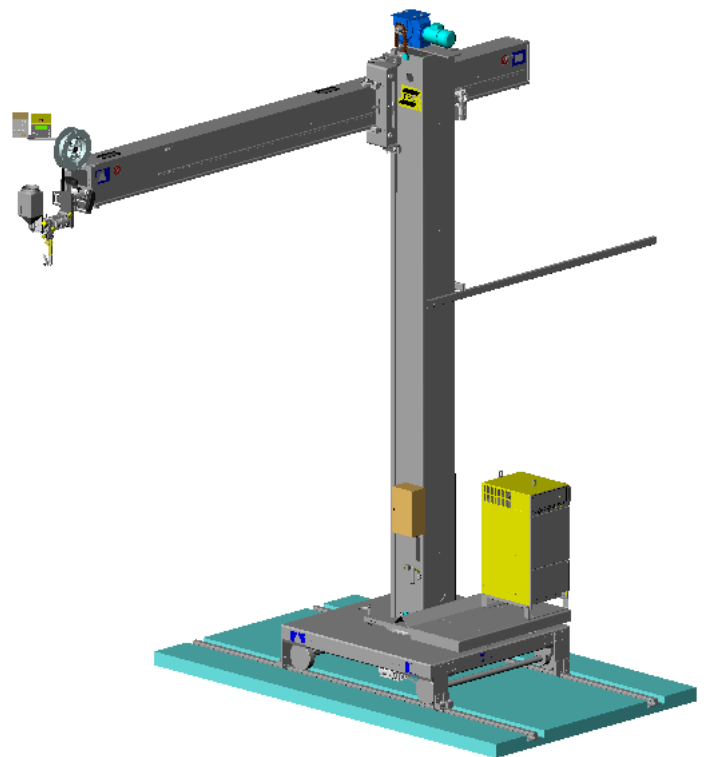

CaB 460S

Choose a rectifier or transformer of the power source family, LAF or TAF, and a complete welding station has quickly been assembled - a very cost efficient and highly productive piece of equipment. The welding Process Controller PEH can also regulate speed with ESAB handling tools and is prepared for quality supervision with Weldoc WMS 4000 system.

...and safety

The low control voltage, 42V, makes it possible to weld in damp and confined areas. In case of an emergency, there are several emergency stops at various locations on the station for a quick shutdown of the system. An anti-fall guard immediately locks the boom in the event of breakdown. Anti-tilting device on the mobile carriage as protection in case of collision accidents.

Technical data, Column

Effective working range (m)	5	6	7
Boom height A (max mm)	5950	6950	7950
using movable carriage (min mm)	950	950	950
Boom height B (max mm)	5845	6845	7845
using concrete stand (min mm)	845	845	845
Boom height C (max mm)	5510	6510	7510
using stationary foot plate (min mm)	510	510	510
Total height D (mm)			
using movable carriage	7275	8275	9275
Total height E (mm)			
using concrete stand	7170	8170	9170
Total height F (max mm)			
using stationary foot plate	6835	7835	8835
Lifting speed (m/min)	2.0	2.0	2.0
Total load on column platform (max kg)	1500	1500	1500
Total weight incl. saddle (kg)	1740	1880	2020

Technical data, Boom

Effective working range (m)	5	6	7
Extension G (max mm)	5715	6715	7715
(min mm)	715	715	715
Permissible loads			
-total (max kg)	1050	1000	950
-one end (max kg)	450	350	150
Cross-sectional diameter H (mm)	630	630	630
Welding speed (m/min)	0.1-2.0	0.1-2.0	0.1-2.0
Transport speed (m/min)	2.0	2.0	2.0
Total weight incl. cables (kg)	590	670	750

Technical data, Rail carriage

Track width L , inside to inside (mm)	1730
Width x length (mm)	2100x2380
Height I (mm)	485
Welding speed (m/min)	0.1-2.0
Transport speed (m/min)	2.0
Total weight (kg)	2860

Technical data, Concrete stand

Width x length (mm)	2100x2410
Height J (mm)	380
Total weight (kg)	2900

Technical data, Foot plate

Width x length (mm)	1600x1600
Height K (mm)	40
Total weight (kg)	505

Ordering information

Working range	Rail carriage Part no.	Stationary Part no.	Foot plate mounted Part No.
5x5	0810 057 888	0810 057 908	0810 057 928
6x6	0810 057 890	0810 057 910	0810 057 930
7x7	0810 057 892	0810 057 912	0810 057 932

Prepared for camera:

5x5	0810 057 948	0810 057 968	0810 057 988
6x6	0810 057 950	0810 057 970	0810 057 990
7x7	0810 057 952	0810 057 972	0810 057 992

Other combinations of working ranges and foundations on request.

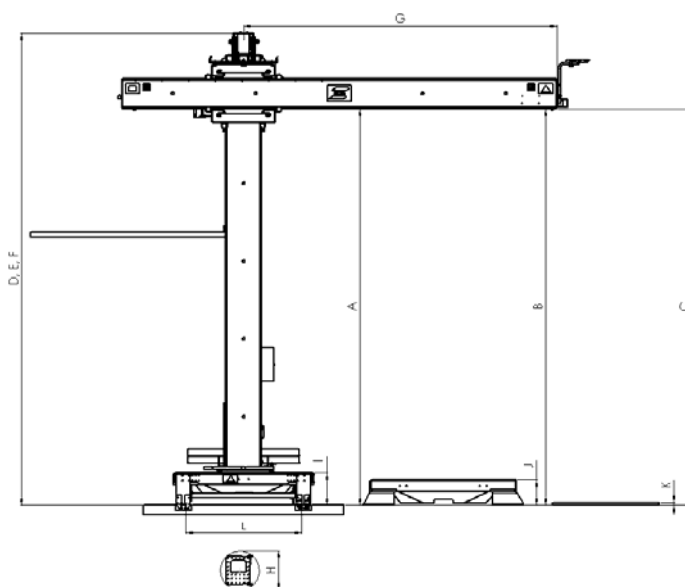

Approved welding equipment for CaB 460S fully adapted modules

Joint tracking and positioning
PAV Joystick control or
GMH Joint tracking with
electromechanical sensor

Options
Camera system
Flux valve control
Tacho regulated drives

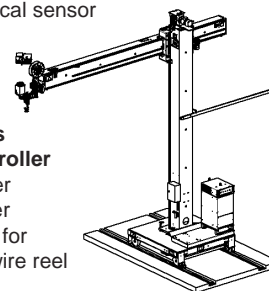

Welding heads with PEH controller
A2 S Minimaster
A6 S Arc Master
and equipment for
rear mounted wire reel

Accessories for the following systems:
A2 GMAW
A2 SAW
A6 SAW

Flux handling equipment
OPC Super
FFRS Super

Power sources

Power source	welding cable dim.	Welding cable dim.
LAF 635 Arc Power		1x120 mm ²
TAF 800 Arc Power	-"	2x95 mm ²
LAF 1000 Arc Power	-"	2x95 mm ²
LAF/TAF 1250 Arc Power	-"	2x120 mm ²
LAF 1600 Arc Power	-"	3x120 mm ²



ESAB AB
Welding Equipment
SE-695 81 LAXÅ SWEDEN
Phone: +46 584 81000
Fax: +46 584 411721
E-mail: info@esab.se
www.esab.com

